

FLOOR CLEANING LINES

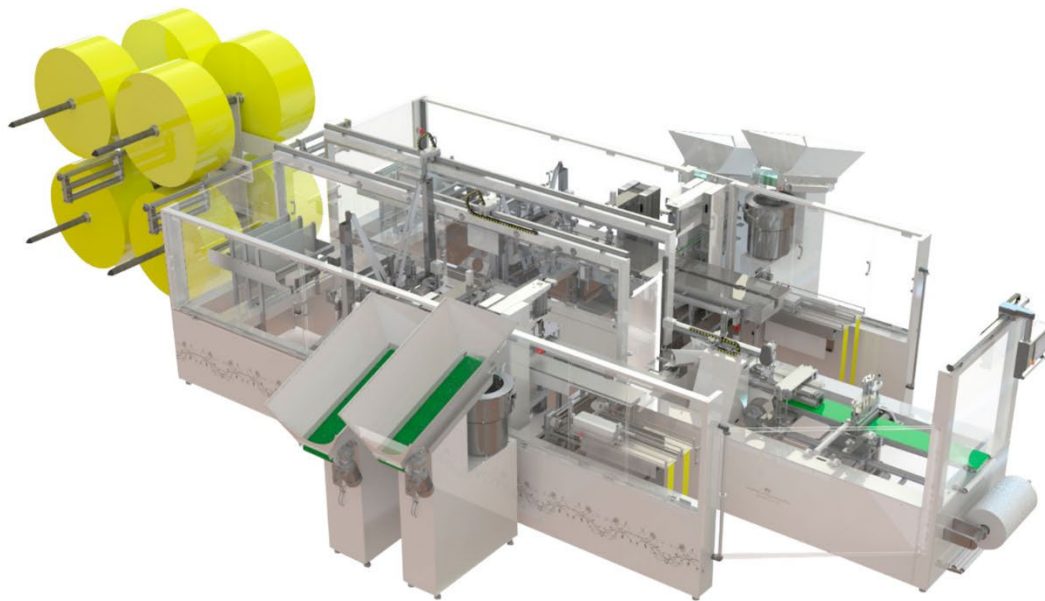

“OMEGA W TRAIN”

During the course of more than 30 years in the manufacture of machinery, our premise has always been the quality of our products. We know that perfection does not exist, but we are sure that we strive for it with perseverance and determination.

In the last decade, our evolution has taken us to the technological top at international level, being to date, the first company to manufacture production lines in all the sectors in which we are represented.

Thank you for trusting in our perseverance



CEO - José Ferrando García

DESCRIPTION

Double production line for the manufacture of fan-shaped fibre floor cleaners.

This production line is a set of interlinked machines which are synchronised to form a single system, enabling all the processes necessary for the manufacture and bagging of the product to be carried out.

TECHNICAL CHARACTERISTICS

- **STRUCTURE**

Formed steel structure. Currently all Jofesa machines are manufactured with structure finished in electrogalvanised and fire-lacquered paint.

- **LIGHTING**

Lighting with 5050 LED strip lights, with RGB colour change (green, blue and red) throughout the machine, which increases communication between the operator and the machine. Energy saving and environmental protection.

- **CONTROL**

New OMRON SYSMAC automation platform. Currently all Jofesa machines are installed with this new platform from the smallest to the largest machines with the same controller, which provides the speed, flexibility and scalability necessary for today's industry.

This allows us to expand our machines without the need to change the installation. The controller, based on the new INTEL CPUs, integrates drive, logic, safety and vision all programmed from the same software with 128 axis / 250 μ s cycles.

Our machines have two communication buses:

- **Ethercat** (Can based on Ethernet): the fastest machine network on the market, with which we connect to all machine devices without the need for complicated wired installations.
- **Ethernet-IP** a very robust and fast industrial Ethernet bus to which the machine's touch terminals are connected, from which all the machine's settings and parameters are controlled and selected, and which we can connect to our customers' network to collect all the necessary information (Industry 4.0).

Each module of the machine has its own control panel, which communicates with the CPU via a single ethercat cable. The servomotors, inputs, outputs, safety, machine vision and all the pneumatics are controlled via this bus.

The sysmac platform also integrates the safety solution, both the safety controller (specific safety CPU) and the safety inputs/outputs are freely distributed throughout the machine, simplifying the installation, as well as the monitoring of the safety status on the touch terminals.

- **MOTORISATION**

The heart of our machines are the Accurax G5 servo systems, the perfect combination of control and mechanics. The control of movements is mainly carried out by servomotors, all the drivers that control the servomotors, in addition to the Ethercat bus, incorporate a safety input in accordance with performance level D of ISO13849-1.

They are controlled by a Motilon Control CPU, allowing us to perform interpolations, Cam tables or electronically connect axes with each other, making the most difficult tasks easy.

In addition, where a servomotor is not necessary and a simple motor is sufficient, this will always be controlled by MX2 series drives, with open-loop torque control, which allows us to control them from speed 0, with safety inputs to disconnect the motors when the safeties are open.

- **DETECTION AND VISION**

Our colour or contrast sensors are also integrated into Sysmac and connected via the Ethercat machine bus, allowing us to program, configure and display any photocell from the touch terminals, as well as providing ultra-fast response speeds.

- **PNEUMATICS**

Pneumatic motion control is also integrated, based on the fully configurable and scalable FESTO-MPAL terminals and connected via the Ethercat machine bus. All solenoid valves can be activated manually from the machine's touch terminals and the actuation times can be adjusted.

Approximately 90% of the pneumatic actuators are manufactured exclusively for the required performances, with a patented pneumatic system (COMPAC SYSTEMS) that optimises the space and application of the system, facilitating changeover and maintenance with a proprietary changeover system.

- **SOFTWARE MAINTENANCE**

All this with a single software from which everything is controlled and which can be accessed via the internet to monitor changes to the programme or maintenance tasks.

- **MANUALS AND REGULATIONS**

Manuals and CE regulations and a CD with all the components of the machine in three dimensions is included, which allows maintenance and changes to be made, visualising the components without having to dismantle the machine.

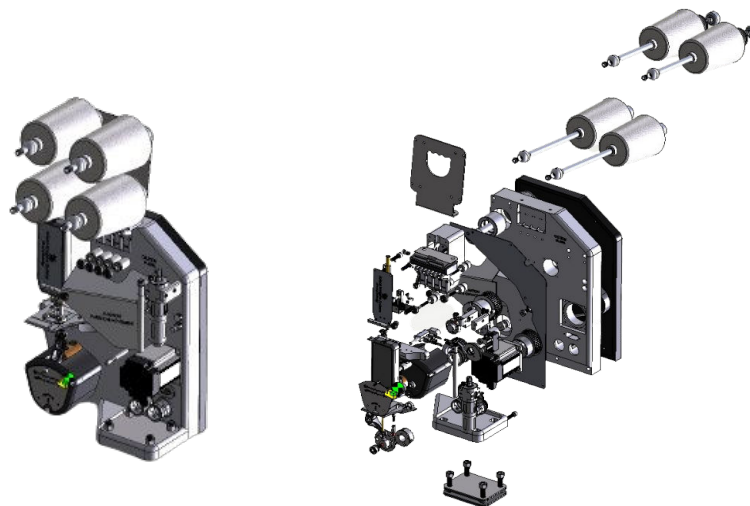

PROCESSES

- Feeding silos
- Strip cutting system
- Fan rotation system
- Three material distribution manipulators
- Assembly system with cup and fork feeding system
- Single or double bagging system (Optional)
- Cardboard sash system (Optional)
- Perforation system for handle (Optional)
- Thermal hanger system (Optional)

PRODUCTION AND CONSUMPTION

- Production - 2100 pcs/h
- Packs production - 1050 pack 2 Ud/h
- Electric power - 9 Kw
- Pneumatic consumption - 2250 l/min
- Voltage 220/380 v

ADDITIONAL MODULES

- Cardboard sash module
- Printing module
- Duplo bagging module
- Hanger perforation module
- Ethernet connection
- Embedding

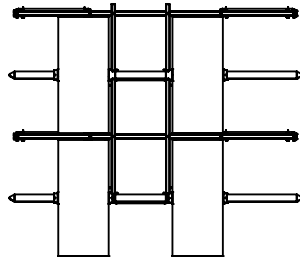
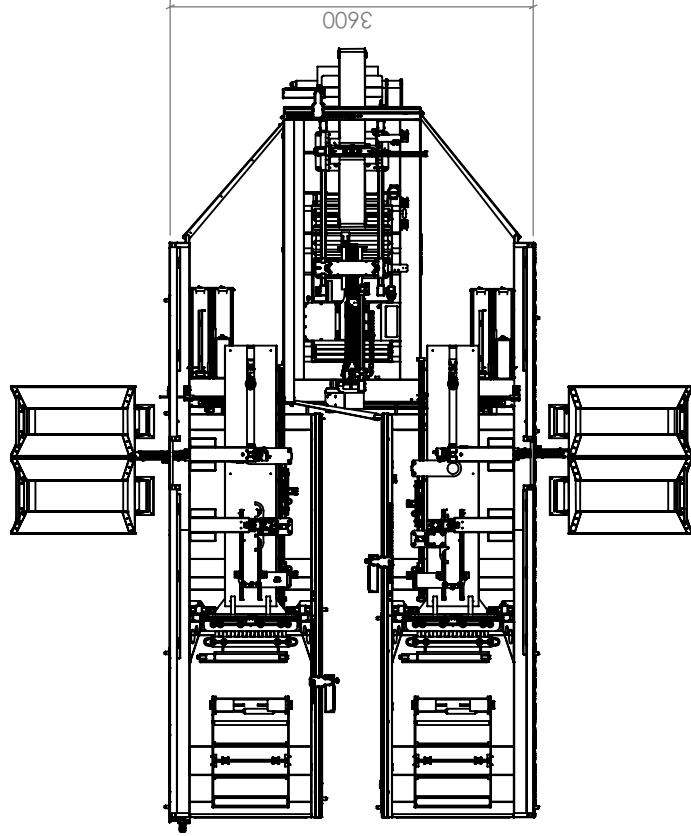
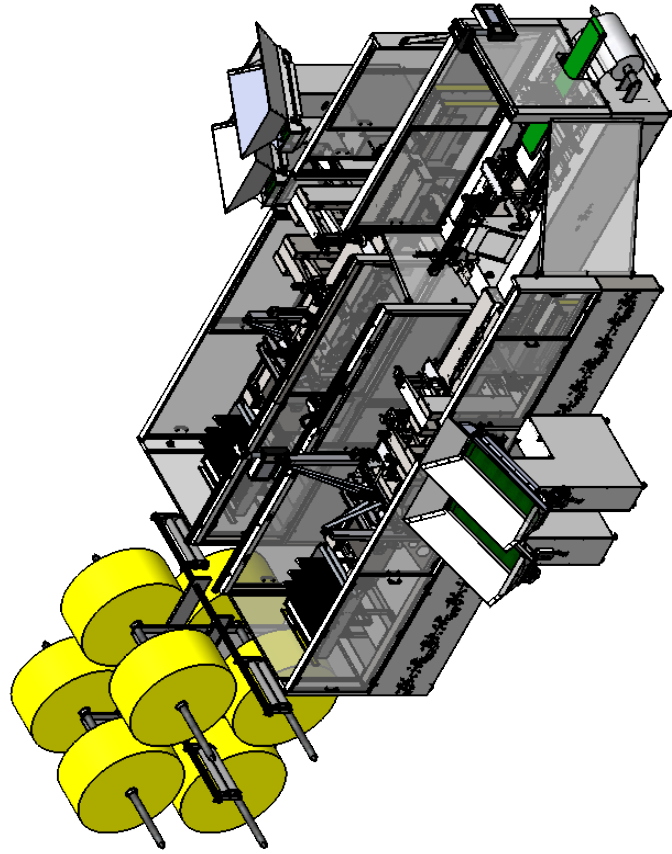
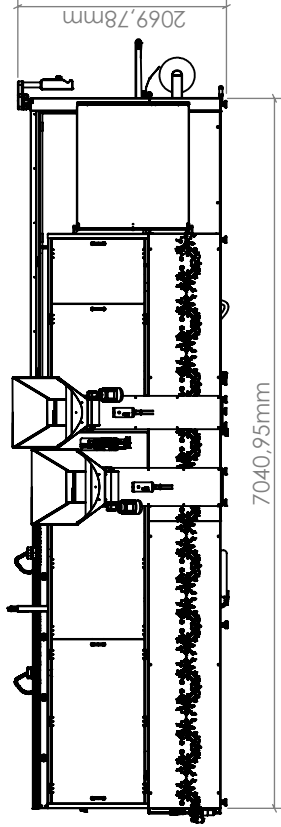
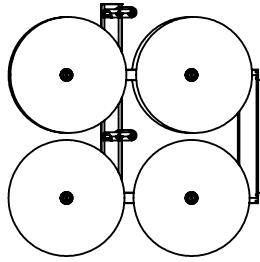
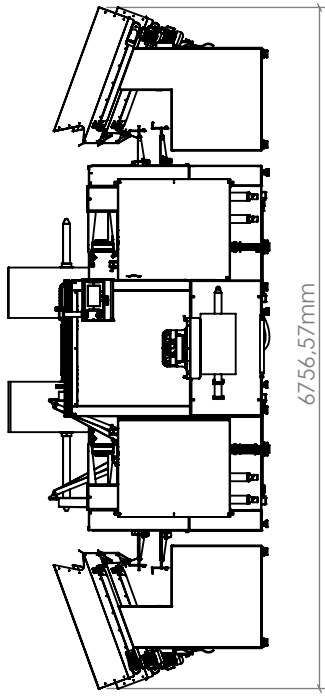

Descripción: Tren Omega 2015

Material: --

Tipo: 29/04/2021

Observaciones: --

Cantidad: --

Escala: 1:75

Acabado

